

G100 LOAD BINDER RATCHET LEVER STYLE

SPECIFICATION FOR 8MM TO 13MM



G100 Load Binder Ratchet Lever Style

Ratchet style load binder with winged grab hooks combined with Grade **100, 80 or 70** chain are an effective way to restraint heavy loads for transport operations, with the benefit of high pretension and the added safety of screw stops to ensure full thread contact while in use.

- Manufactured from dropped forged steel quenched and tempered.
- Marked with chain size, lashing capacity, grade, batch numbered and branded Austlift for traceability.
- All load binders come with swivel winged grab hooks to achieve full lashing capacity.

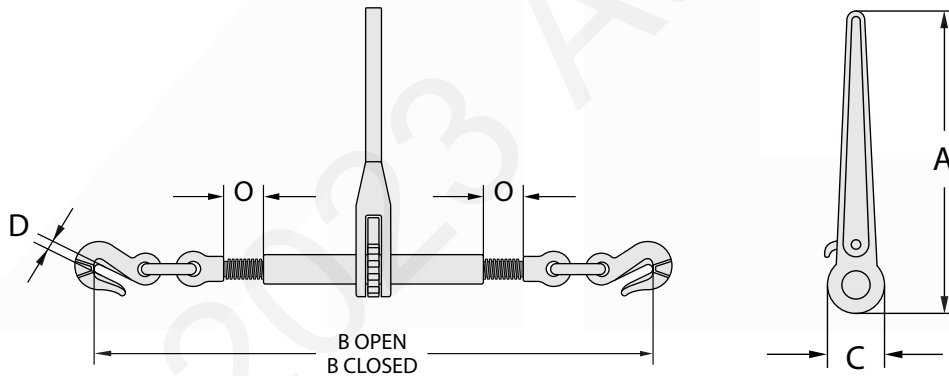

CHAIN SIZE (mm)	CODE	LASHING CAPACITY (kN)	MBF (kN)	WEIGHT (kg)	DIMENSIONS (mm)					
					A	B		C	D	O (MAX)
						OPEN	CLOSED			
8	202308	50	100	4.6	371	744	584	63	10.5	80
10	202310	80	160	5.6	371	769	604	63	12.5	80
13	202313	134	268	7.9	371	852	702	63	15.5	80

AUSTLIFT Lifting your business to a higher level.

NSW Head Office

43 Frank Street
 Wetherill Park, NSW 2164
 02 9757 2277

WA Office

42 Mulgal Road
 Malaga, WA 6090
 08 9248 6674

QLD Office

7 Durbell Street
 Acacia Ridge, QLD 4110
 07 3272 0777

VIC Office

475 Dohertys Road
 Truganina, VIC 3029
 03 9314 5525