

KITO PWB® MULTI-DIRECTIONAL EAGLE® LIFTING CLAMPS MODEL SBB & SBBA



Applications

- ✔ Lifting, transporting, suspending, turning, rotating, welding, assembling, erecting, loading, pressing, lifting pieces, bending, pulling pieces, safety belt mounting pieces.
- ✔ Loading materials: steel plates, shaped-steel, flat steel, steel joists, iron-frames, bridges, steel structures, columns, steel frames, steel sheet piles, formed heads, pipes, transverse members for shipbuilding, etc.

Twin shackle for all-direction pulling, handy for shifting irregular-shaped objects. Clamp screw can be tightened using ratchet wrench.

Features

- ✔ For horizontal and vertical lifting applications.
- ✔ Spring type pressure locking device.
- ✔ Twin shackle allows for movement in any direction.
- ✔ Double safety feature with screw type vice and automatic clamping mechanism.
- ✔ Forged special alloy steel body with galvanised finish.
- ✔ Manufactured in Japan by Eagle Clamp.

Capacity: 0.5 – 5.0T

Australian Standard: AS 4991

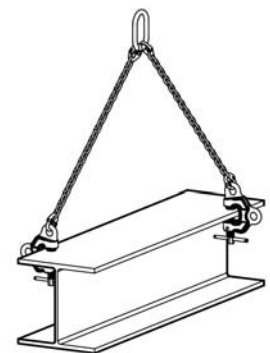

KITO PWB® Multi-Directional Eagle® Lifting Clamps

Specifications

> Model SBB

- ✔ Clamp screw and swivel jaw made of induction hardened, alloy steel.
- ✔ Tightening force must be minimum of 14.7Nm.
- ✔ Attachment and detachment are easily performed with the patented spring collar.



Model SBB



Model SBBA

> Model SBBA

- ✔ Clamp screw, edge pad and swivel jaw made of induction hardened, alloy steel.
- ✔ For steel plates with higher hardness range.
- ✔ Tightening force on SBBA must be minimum of 29.4Nm.

Part No.	Model	WLL (tonnes)	Hardness Range (Vickers)	Effective Thickness (mm)	Weight (kg)
44925	SBB-05	0.5	Hv 85-320	1-25	1.8
44926	SBB-1	1.0	Hv 85-320	1-40	4.0
44927	SBB-2	2.0	Hv 85-320	1-40	7.6
43497	SBB-3	3.0	Hv 85-320	5-35	8.3
43496	SBB-5	5.0	Hv 85-320	10-40	14.3
44932	SBBA-05	0.5	Hv 85-600	1-25	1.8
49600	SBBA-1	1.0	Hv 85-600	1-40	4.0
49601	SBBA-2	2.0	Hv 85-600	1-40	7.6
49602	SBBA-3	3.0	Hv 85-600	5-35	8.3

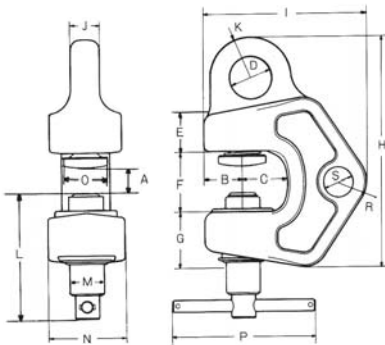

Model	B (mm)	C (mm)	D (mm)	E (mm)	F (mm)	G (mm)	H (mm)	I (mm)	J (mm)	K (mm)	L (mm)	M (mm)	N (mm)	O (mm)	P (mm)	Q (mm)	R (mm)	S (mm)
SBB-05	23	25	27	22	41	29	140	112	15	24	96	20	46	26	150	15	24	27
SBB-1	30	45	32	31	61	46	203	166	18	34	124	24	55	36	150	22	34	32
SBB-2	37	43	36	44	66	46	218	185	25	38	134	32	74	44	150	25	36	32
SBB-3	40	47	45	40	60	60	240	170	30	43	137	36	80	50	150	30	30	31
SBB-5	48	55	50	45	70	70	276	213	35	47	150	40	96	60	150	35	45	37
SBBA-05	23	25	27	22	41	29	140	223	15	24	96	20	46	26	150	15	24	27
SBBA-1	30	45	32	31	61	46	203	166	18	34	124	24	55	36	150	22	34	32
SBBA-2	37	43	36	43	66	45	210	183	25	38	134	32	70	44	150	25	36	32
SBBA-3	40	47	45	40	60	60	240	170	30	42	137	36	80	50	150	30	30	31

KITOPWB

Premium Quality Products

For more information:

Call 1300 792 262

Visit www.kitopwb.com.au

Head Office

441 Grimshaw Street,
Bundoora, VIC 3083

Tel: 1300 792 262 Fax: 03 9467 7290

Email: vicsales@kitopwb.com.au

QLD Office

1/119 Bandarra Street,
Richlands, QLD 4077

Tel: 07 3375 1288

Email: qldsales@kitopwb.com.au

WA Office

2/11 Mallaig Way,
Canning Vale, WA 6155

Tel: 08 9256 2499

Email: wasales@kitopwb.com.au