

JC-1050-16F03

JC-1050-21F05

TECHNICAL DATA SHEET

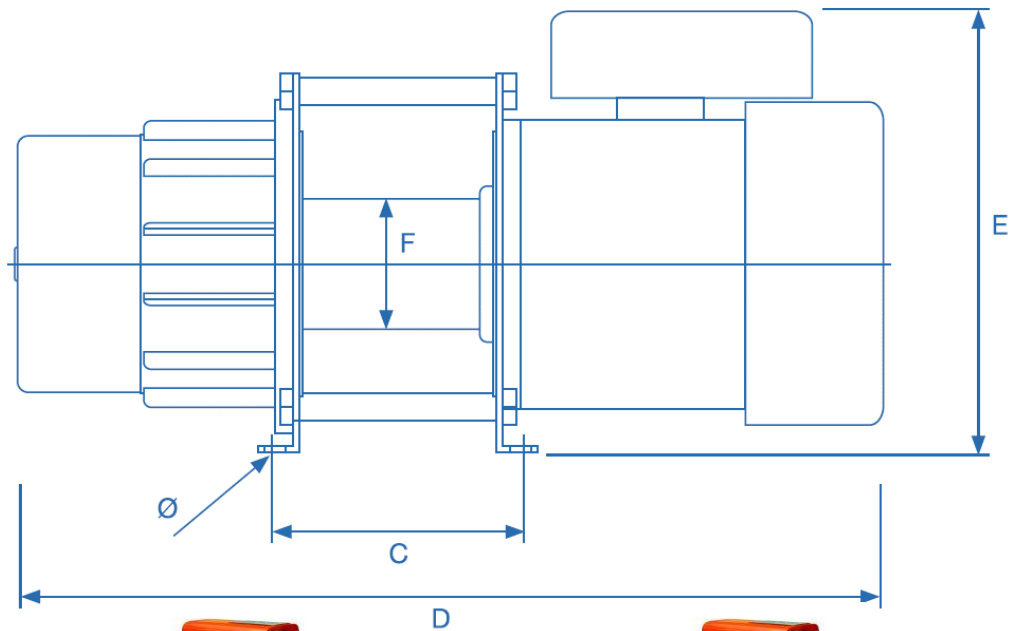
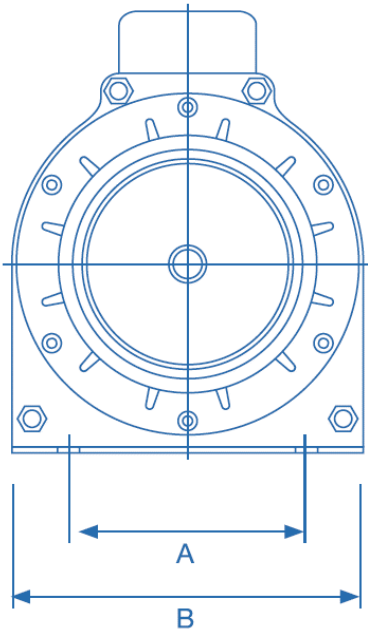

Model	JC-1050-16F03	JC-1050-21F05	
Capacity	500	500	
Avg Speed (M/min)	13	17	
Steel Rope Capacity	8mm x 30m	8mm x 50m	
Voltage	1PH 240V AC 50Hz	1PH 240V AC 50Hz	
Motor kW	1.6 kW	1.8 kW	
Body Dimensions (mm)	A	160	160
	B	220	250
	C	186	206
	D	613	653
	E	305	315
	F	78	105
	∅	13	17
Weight (kg)	48.5	58.7	



WINCHES AUSTRALIA
Quality Winch Solutions



1300 946 242

www.heswinches.com.au